

A - A

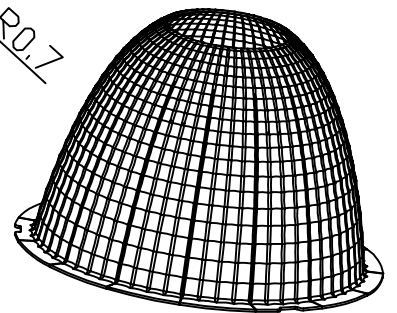

Light Source	LUMILEDS 1205
Plastic Holder	92.70.411.00
Metal Adapter	
Design Angle	$36^\circ \pm 3^\circ$
Measured Angle	36.6°
Efficiency	

光学装配示意图

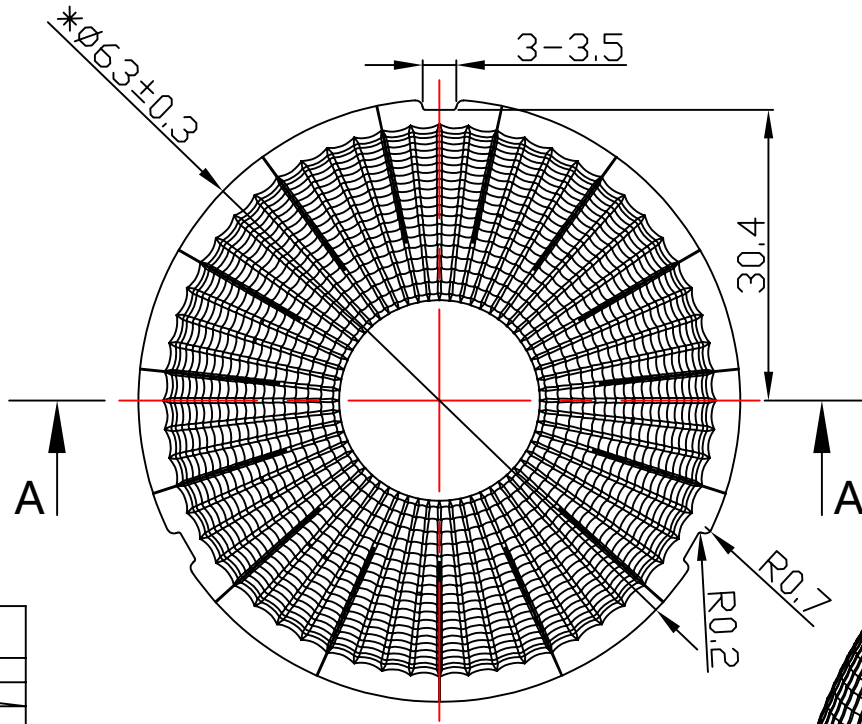
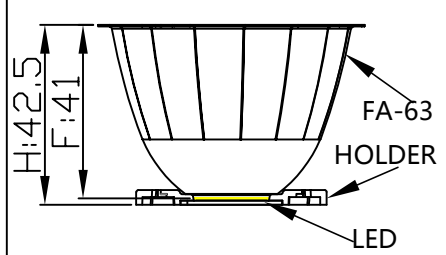

- Technical requirements:
- 1.MATERIAL: T=0.4mm High reflectivity aluminum(Mirror surface).
 - 2.**KEY CONTROL DIMENSION.
 - 3.Tolerances not noted are in accordance with the tolerance table.
 - 4.unmarked rounded corners Press for 3D.
 - 5.Surface without imprint, black spots, cracks, wrinkles and other poor.

标记 MARK	处数 NO.OF MODIF	更改内容 MODIFICATIONS	签名 SIGNED BY	更改日期 MODIF. DATE
设计 DESIGNER	制图 DRAWN BY	比例 SCALE	1:1	
工艺 TECHNICIAN	审核 CHECKED BY	视角 1st ANGLE PROJECTION		
批准 APPROVED BY	日期 DATE(DD-MM-YYYY)	页数 PAGE	SHEET 1 OF 1	

DIMENSION TOLERANCE TABLE (UNLESS OTHERWISE STATED)						
> 0-5	> 5-30	> 30-90	> 90-150	> 150-250	> 250-400	> 400-700
±0.15	±0.2	±0.4	±0.5	±0.8	±1.5	±2
PUNCH TOLERANCE TABLE (UNLESS OTHERWISE STATED) (ANGLE)						
> 0-10	> 10-50	> 50-120	> 120-250	> 250-360		
±1°	±0.5°	±0.3°	±0.2°	±0.166°		
产品图 PRODUCT DRAWING						

Nata [®]		版本 VERSIONS
		K
产品编码 PRODUCT CODE	91.02.2456.000	
产品名称 PRODUCT NAME	2-2456-L	
客户代号 CUSTOMER ID	NT	
客户编号 CUSTOMER CODE	FA-63-36D	

单位
UNIT
mm